

Solar Energy Monitoring System by IOT

K.G.Srinivasan

Research Scholar, Velammal Engineering College, Chennai.

Email: kgsrinivasanped@gmail.com

Dr.K.Vimaladevi

Professor CSE, Velammal Engineering College, Chennai.

Email:k.vimaladevi@gmail.com

Dr.S.Chakravarthi

Associate Professor CSE,

Velammal Engineering College, Chennai.

Email: chakra2603@gmail.com

ABSTRACT

The Internet of Things has a vision in which the internet extends into the real world, which incorporates everyday objects. The IoT allows objects to be sensed or controlled remotely over existing network infrastructure, creating opportunities for pure integration of the physical world into computer-based systems, and resulting in improved efficiency, accuracy and economic benefit in addition to reduced human intervention. This technology has many applications like Solar cities, Smart villages, Micro grids and Solar Street lights and so on. As Renewable energy grew at a rate faster than any other time in history during this period. The proposed system refers to the online display of the power usage of solar energy as a renewable energy. This monitoring is done through raspberry pi using flask framework. Smart Monitoring displays daily usage of renewable energy. This helps the user to analysis of energy usage. Analysis impacts on the renewable energy usage and electricity issues.

Keywords- Renewable energy; IoT; flask; Cloud;

I. INTRODUCTION

The Internet of Things (IoT) is a system of related computing devices, digital and mechanical machines, objects, people with unique identifiers and potential transfer of data over a network without human-to-human or human-to-computer interaction. Physical objects those are no longer disconnected from the virtual world, but can be controlled remotely through Internet services.

A smart world is nothing but Smart devices, Smartphones, Smart cars, Smart homes and Smart cities. "Smart" objects play a key role in the vision of IoT, since embedded communication and information technology would have the potential to revolutionize [12]. With the growing presence of WiFi and 4G-LTE wireless Internet access, the evolution towards omnipresent information and communication networks is already evident [13]. According to the International Energy Agency (IEA), Renewable energy will be the fastest-growing source of electricity, in which wind and solar PV are technologically mature and economically affordable. But still there is increase in world's demand for energy. Adopting Renewable Energy technologies is one of the advance ways of reducing the environmental impact.

The latest edition of the IEA's Medium-Term Renewable Market Report specifies the renewable energy growth about 13% more between 2015 and 2021 than it was in last year's. The share of renewable energy in overall electricity generation will rise from over 23% in 2015 to almost 28% in 2021.

Solar energy is universally available all over the world and can contribute to minimize the dependence of energy imports. In 90 minutes, enough sunlight strikes the earth to provide the entire planet's energy needs for one year. Solar

PV leads to no greenhouse gas (GHG) emissions and other pollutants during operation. Solar has many benefits like system-friendly deployment, improved operating strategies, advanced renewable energy forecasting and enhanced scheduling of power plants and also investment in additional flexible resources, comprising demand-side resources, electricity storage, grid infrastructure and flexible generation.

The traditional method focuses on the levelized cost of electricity (LCOE) which is a measure of cost for a particular generating technology at the level of a power plant that is no longer sufficient. About a million solar panels were installed every day around the world last year. Solar PV leads providing almost 40% of global renewable electricity capacity growth over the medium-term.

Finally, in analyzing the evolution of electricity and energy-consuming sectors, it explores the prime role solar energy could play in the long-term future of our energy system.

Applications of the monitoring system are the Rooftop Solar, Ground mounted Solar, Solar cities, Smart villages, Micro grids and Solar Street lights. Consumer Products like solar water heating systems, Solar home lighting systems, solar lanterns, solar pumps, solar mobile chargers, solar cookers, LED solar torch, solar RO plant, solar fan, solar Inverters, etc. can be monitored through this project. Commercial Products like Solar traffic signals, solar road studs/blinkers can also be monitored through the proposed system.

In India, frequent power cut is very common. Due to this issue, it is important to use renewable energy and monitoring it. By monitoring the energy forecast, households and communities who are using solar power

can utilize their energy production and consumption during good weather.

This paper is organized into five main sections: In Section I we have briefly introduced about the domain. Section II discusses the literature survey in this area. Section III discusses the proposed work done. Section IV discusses the Results and Discussions. Section V summarizes the conclusion and lastly, the references used in writing this paper.

II. LITERATURE SURVEY

Purusothaman, SRR Dhiwaakar, et al: Explain about the focus is on the DG agents, grid agent and Mu agents. DG agents like the distributed energy resources (DERs), load, storage and the grid agents. The Mu agent acts as the communication channel between the DG agents to the higher level agents such as the control agent. The implementation of the system has been done using an Arduino microcontroller.

Author Kabalci, Ersan, Alper Gorgun, and Yasin Kabalci: Introduces An instant monitoring infrastructure of a renewable energy generation system that is constituted with a wind turbine and solar panel arrays. The monitoring platform is based on current and voltage measurements of each renewable source. The related values are measured with the developed sensing circuits and processed by an 18F4450 microcontroller of Microchip. The processed parameters are then transmitted to a personal computer (PC) over universal serial bus (USB) to be saved in a database and to observe the system instantly. The coded visual interface of monitoring software can manage the saved data to analyze daily, weekly and monthly values of each measurement separately.

Jiju, K., et al: Describes the development of an online monitoring and control system for distributed Renewable Energy Sources (RES) based on Android platform. This method utilizes the Bluetooth interface of Android Tablet or Mobile phone, as a communication link for data exchange with digital hardware of Power Conditioning Unit (PCU).

Goto, Yoshihiro, et al [4] explained about an integrated system that manages and remotely monitors telecommunications power plants has been developed and has started operations. The system is used to operate and maintain more than 200,000 telecommunication power plants, which including devices such as rectifiers, inverters, and UPSs, and air-conditioning plants installed in about 8,000 telecommunication buildings. Features of the system are the integrate the management and remote monitoring functions, into one system and improved user interfaces, which use information and communication technology such as web technology.

Suzdalenko, Alexander, and Ilya Galkin: Identify the problem of the non-intrusive load monitoring method of

load disaggregation into separate appliances. When some local generators based on renewable energy sources are connected to the same grid, as they may be mismatched with loads variable in time.

Nkoloma, Mayamiko, Marco Zennaro, and Antoine Bagula: Describes recent work on the development of a wireless based remote monitoring system for renewable energy plants in Malawi. The main goal was to develop a cost effective data acquisition system, which continuously presents remote energy yields and performance measures. The project output gives direct access, to generated electric power at the rural site through the use of wireless sensor boards and text message (SMS) transmission over cellular network. Preliminary experimental results reveal that the performance of renewable energy systems in remote rural sites can be evaluated efficiently at low cost.

Nkoloma, Mayamiko, Marco Zennaro, and Antoine Bagula: are proposes a novel monitoring, control system for achieving real time monitoring and control of a hybrid 'wind PV battery' for renewable energy system. The proposed system constitutes a supervisory control and data acquisition (SCADA) system, which employs campus network of National Cheng Kung University integrated with a programmable logic controller (PLC) and digital power meters. The proposed system is capable of performing real time measurement of electrical data that can be effectively transferred to remote monitoring center using intranet. It can be concluded from the simulated and experimental results that the proposed monitoring and control system can achieve real time supervisory control and data acquisition of remote various forms of renewable energy system.

III. PROPOSED WORK

The main objective of this proposed work is to Power of the system can be monitor using the current and voltage value sensed by the arduino. The monitor of the solar energy system shows the power and energy usage. This system helps to implement in smart grid for efficient usage.

3.1. Methodology

In In this section we present the system design of the Solar Energy Monitoring System.

System Design: The proposed system is for monitoring of solar energy using IoT. Solar panel helps to store the energy in the battery. Battery has the energy which is useful for the electrical appliances. Battery is connected to the Arduino. Arduino is a micro controller which is used to read the sensor values. Current sensor and voltage divider are connecting to the Arduino.

Arduino is connected to Raspberry pi through USB cable. Raspberry pi(RPi) is working as a server. The data from the arduino is display on the web page through RPi. The monitoring data upload to the cloud through RPi as shown in the Fig 1.

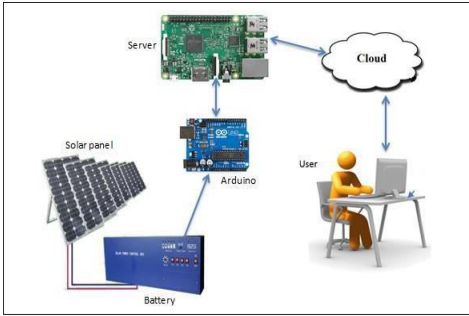

Fig 1. System Design

3.1.1. Arduino

Keeping in mind the economic constraints and the simplicity of the system, Arduino Uno has been used which abates the programming complexity. Arduino sense the current and voltage value through Analog pins. With the help of these values, Arduino programing calculates the power and energy.

3.1.2. Raspberry Pi

Raspberry Pi is used in the project as a central monitoring system. As Raspberry pi board is a portable and low cost, it reduces the system cost. As python is most used high level, general purpose, and interpreted, dynamic programming language. This project use python as the programming language in the Raspberry Pi. Python web applications have one central callable object that implements the actual application. In Flask this is an instance of the Flask class. With the help of python program monitoring data is upload to the cloud.

Flask is a lightweight web application framework, which is written in Python and based on the WSGI toolkit and Jinja2 template engine. Flask using the flexible Python programming language and provides a simple template for web development.

Rpi has the inbuilt wifi. With the internet RPi displays the data on the web page and stores the data on the cloud. The cloud has public access so the user can access the monitoring. The user can estimate the usage and available of the battery.

3.1.3. Current and Voltage Acquisition Circuit

The analog inputs of an Arduino can measure up to 5V. To protect the Arduino from short-circuits or unexpected voltage surges, we use resistor while connect to the 5V circuit. The circuit of voltage divider is shown in the Fig 2. Two resistors form a potential divider that helps to lower the voltage being measured to a level that the Arduino can read. Fig shows the voltage divider circuit. 10kohm and 100kohm register are used to reduce the voltage circuit to 5V. Analog pin of arduino gives the voltage value. Breadboard is used to build this circuit which actually extends the range that can be used.

The formula for calculating values in a potential divider is: $V_{out} = [R2 / (R1 + R2)] * V_{in}$

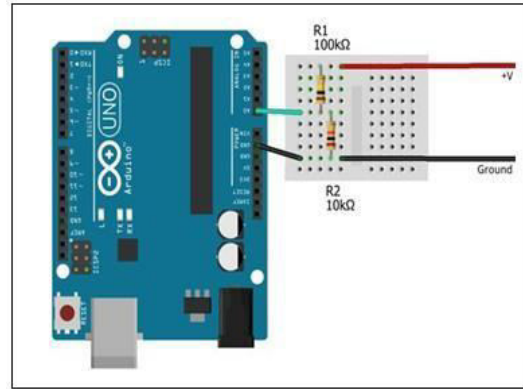

Fig 2. Voltage Divider

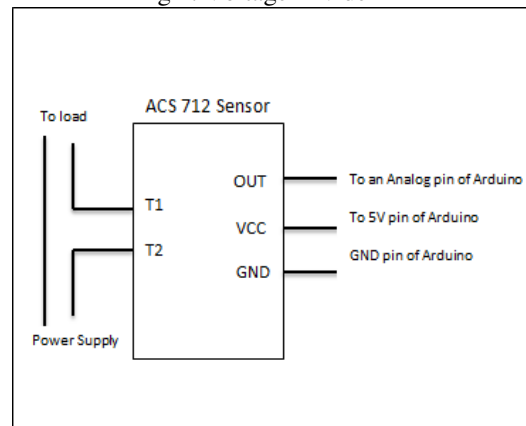

Fig 3. Current Sensor circuit

If the divider for the Arduino voltmeter is functioning correctly, then V_{out} will be a maximum of 5V. So we can calculate the maximum input voltage to the circuit:

$$V_{max} = 5.0 / [R2 / (R1 + R2)]$$

For the measurement of current we will use a Hall Effect current sensor ACS 712 (30 A). ACS 712 measure positive and negative 30Amps, corresponding to the analog output 66mV/A. This current sensor gives the readings of the current. Those values are used in the proposed system for calculating power. In this setup DC bulb is consider as a load. Battery is considered as the power supply. Other pins of sensor is connects to the Arduino. Once the connection is done as shown in the Fig 3 , Arduino display the values of current flow.

3.1.4. Temperature sensor

Temperature sensor is used in this project to predict and monitor the solar energy storage. According to the temperature value, the energy storage modulates. Display the temperature values on the web page in the form of gauge.

3.1.5. Cloud Setup

Thing Speak is an open source IoT application and API to store and retrieve data from things using the HTTP protocol over the Internet or via a Local Area Network. ThingSpeak enables the creation of sensor logging applications, location tracking applications, and a social network of things with status updates.

The user should create the account first. The account contains channels which are separate for different projects. Channel has the fields which are different for different parameter in the monitoring system. After assigning the

parameter the system upload the values to it. The cloud has built-in functions in it which represent the values in the form of graphs.

IV. IMPLEMENTATION

4.1. Work Flow

Fig. 4 represents the process of proposed system from load to the monitoring system. The work flow of the solar energy monitoring system is presented in the form of step below.

Step 1: Arduino display the power usage using sensed values through current sensor and voltage divider.

Step 2: Raspberry pi fetch the arduino output data through serial port and display on the web page through python script.

Step 3: Raspberry sends the monitoring data on to the cloud.

Step 4: Cloud display the data in the form of graph, which is visible to the entire user.

4.2. Hardware Setup

Fig 5 shows the Hardware setup of the proposed system. The solar energy stored in battery by solar panel is DC current. So we use DC bulb as the source of power usage. One terminal of the bulb is connected to the battery for power supply. Other terminal is connecting to the current sensor for current reading. Breadboard is used for the complex circuit to build. It also helps to build voltage divider.



Fig 5. Hardware configuration setup
 Arduino sense the current and voltage value through Analog pins. With the help of these values, Arduino programing calculates the power and energy. Output is send to the Raspberry through USB cable. Raspberry pi is considered as the server. The monitor displays the web page and cloud data. The components with specification used in proposed system are listed in Table I below

Table I. Hardware requirements

SI.No	Components	Specifications
1	Operating system	Raspbian OS.
2	External Hard disk	500GB
3	Microcontroller	Arduino UNO 3
4	Processor	Raspberry Pi 3
5	Current sensor	ACS712(30Amp)
6	Temperature sensor	DHT11
7	Registers	10kohm , 100kohm

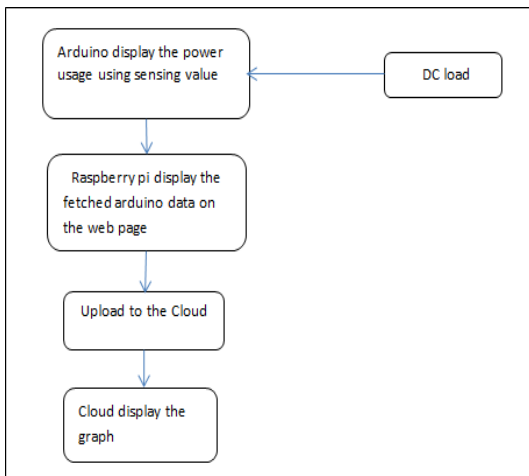

Fig. 4. Work flow of the system

4.3. Software Setup

The open-source Arduino Integrated Development Environment - or Arduino Software (IDE) – is used in system for upload the code on to board. The sensor and circuit are connect to the Arduino for communicate with them to sense current and voltage. We write the code in c for the sensing and calculating the power and energy.

Python is a most used high level, general purpose, interpreted and dynamic programming language. Python2 is used for fetching Arduino data. Python web applications have one central callable object that implements the actual application. In Flask this is an instance of the Flask class.

Using python and Flask, we create web page of monitoring system as shown in Fig 6. The monitoring page displays the table contains voltage, current, power and energy values as shown in Table II. Below the table date and time is displaying.

One link is there to direct to the weather monitoring page which displays the temperature and humidity in the form of gauge shown in the Fig 7. The page is refreshing for every 10 seconds.

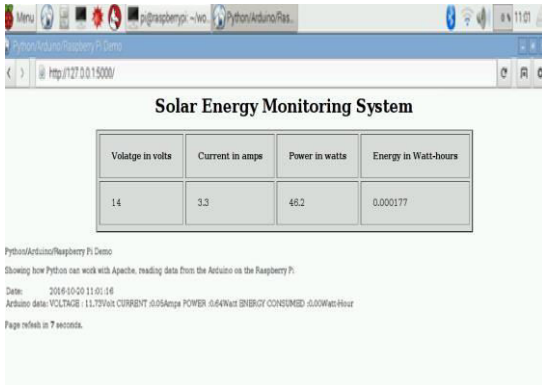

Fig 6. Monitoring Page



Fig.7. Weather Monitoring Page

With the help of python program monitoring data is upload to the cloud. ThingSpeak cloud is used in this project. It is an open source Internet of Things (IoT) application and [API](#) to store and retrieve data. In this cloud we creation the social network of things with status updates.

V. RESULTS AND DISCUSSIONS

The proposed work illustrates results for the Solar Energy Monitoring System.

5.1. Snapshot of Solar Energy Monitoring System Setup

Fig 8 represent the entire hardware setup of the proposed system.

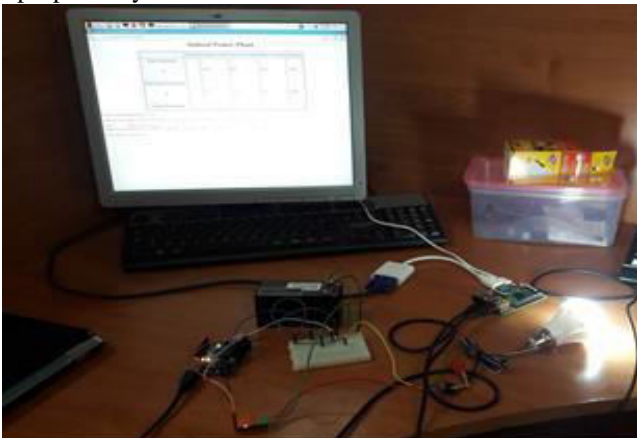

Fig. 8. Hardware configuration setup

5.2. Snapshot of monitoring page in Intranet

Using python and Flask, we create web page of monitoring system. Flask framework code is used to create

web page that can be seen in Intranet using IP address of the Raspberry Pi system. Fig shows the monitoring page displayed on the laptop connected to the intranet as shown in Fig 9.

The result of the system is displayed on the web page in the form of the table contains current in amperes, voltage in volts, power in watts and energy in watt-hours with respect to date and time.

Table II. Power Monitoring Table

SI.NO	Data	Unit
1	Current	Amperes
2	Voltage	Volts
3	Power	Watt
4	Energy	Watt hour

5.3. Graphs

The monitoring data sent to the cloud is store in separate fields. Each fields display the individual graphs as shown in the Fig 10. The graph of the temperature is shown in Fig. 11.

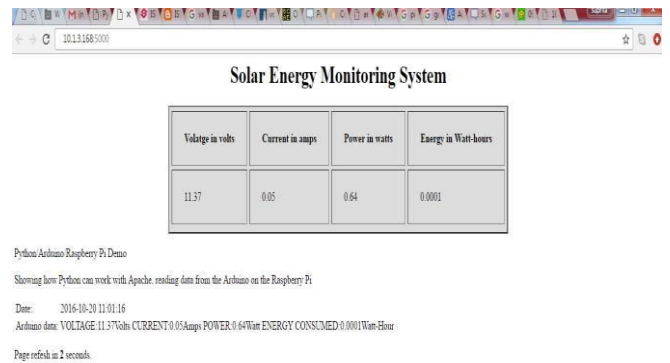

Fig 9 Monitoring Page in Intranet



Fig 10. Current, Voltage, power Energy Graphs

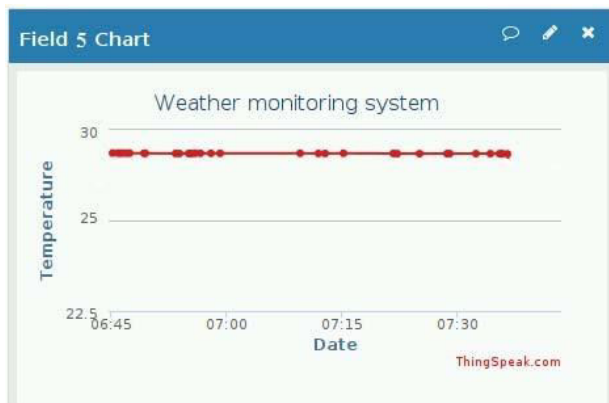

Fig 11. *Temperature Graphs*

Graphs emphasize the main point, make the data more convincing and provide a compact way of presenting information to the users. Graphs are plot for current, voltage, power and energy value with respect to date. These graphs are access through internet from anywhere.

VI. CONCLUSION AND FUTURE WORK

Implementing Renewable Energy technologies is one recommended way of reducing the environmental impact. Because of frequent power cut it is important to use renewable energy and monitoring it. Monitoring guides the user in analysis of renewable energy usage. This system is cost effective. The system efficiency is about 95%. This enables the efficient use of renewable energy. The temperature sensor helps to analysis the storage of the solar energy. Thus it is reducing the electricity issues. This project can be further enhanced, by using the results of this current project, i.e. the monitored values obtained are helpful in predicting the future values of the parameters considered. Prediction of the amount of solar energy will be stored in the battery. The data stored in cloud can also be analyzed using the MatLab. The CSV file from the cloud is taken for analysis in R. The web application can be developed for interaction with the end user; the user can also predict values of the future events. In the same way we can go for android application also. During the prediction two or more models can be used for same dataset, to find the accuracy of each model.

REFERENCES

Purusothaman, SRR Dhiwaakar, et al. "Implementation of Anrduino-based multi-agent system for rural Indian microgrids." 2013 IEEE Innovative Smart Grid Technologies-Asia (ISGT Asia). IEEE, 2013.

[2]. Kabalci, Ersan, Alper Gorgun, and Yasin Kabalci. "Design and implementation of a renewable energy monitoring system." Power Engineering, Energy and Electrical Drives (POWERENG), 2013 Fourth International Conference on. IEEE, 2013.

[3]. Jiju, K., et al. "Development of Android based on-line monitoring and control system for Renewable Energy Sources." Computer, Communications, and Control Technology (I4CT), 2014 International Conference on. IEEE, 2014.

[4]. Goto, Yoshihiro, et al. "Integrated management and remote monitoring system for telecommunications power plants with fully DC-powered center equipment." INTELEC 07-29th International Telecommunications Energy Conference. IEEE, 2007.

[5]. Suzdalenko, Alexander, and Ilya Galkin. "Case study on using non-intrusive load monitoring system with renewable energy sources in intelligent grid applications." 2013 International Conference-Workshop Compatibility And Power Electronics. 2013.

[6]. Nkoloma, Mayamiko, Marco Zennaro, and Antoine Bagula. "SM 2: Solar monitoring system in Malawi." Kaleidoscope 2011: The Fully Networked Human?-Innovations for Future Networks and Services (K-2011), Proceedings of ITU. IEEE, 2011.

[7]. Wang, Li, and Kuo-Hua Liu. "Implementation of a web- based real-time monitoring and control system for a hybrid wind-PV-battery renewable energy system." Intelligent Systems Applications to Power Systems, 2007. ISAP 2007. International Conference on. IEEE, 2007.

[8]. Big data (Dec 2016) Retrieved from <http://bigdata-madesimple.com>

[9]. Internet of things (Nov 2016) Retrieved from

<http://cerasis.com/2015/10/20/10-things-to-know-about-the-internet-of-things>

[10]. "Internet of Things Global Standards Initiative". ITU. Retrieved 26 June 2015.

[11]. "Internet of Things: Science Fiction or Business Fact?" (PDF). Harvard Business Review. November 2014. Retrieved 23 October 2016.

[12]. Mattern, Friedemann, and Christian Floerkemeier. "From the Internet of Computers to the Internet of Things." From active data management to event-based systems and more. Springer Berlin Heidelberg, 2010. 242-259.

[13]. Stankovic, John A. "Research directions for the internet of things." IEEE Internet of Things Journal 1.1 (2014): 3-9.

[14]. Gubbi, Jayavardhana, et al. "Internet of Things (IoT): A vision, architectural elements, and future directions." Future generation computer systems 29.7 (2013): 1645-1660.